

ISO 2768-C GENERAL TOLERANCES
LINEAR AND ANGULAR DIMENSIONS

DIN 6930-C STAMPED STEEL PARTS
FLAT SURFACES / BENDINGS

ISO 13920-BG WELDINGS
WELDED CONSTRUCTIONS

Model
Drawing VFEP101010A.dwg

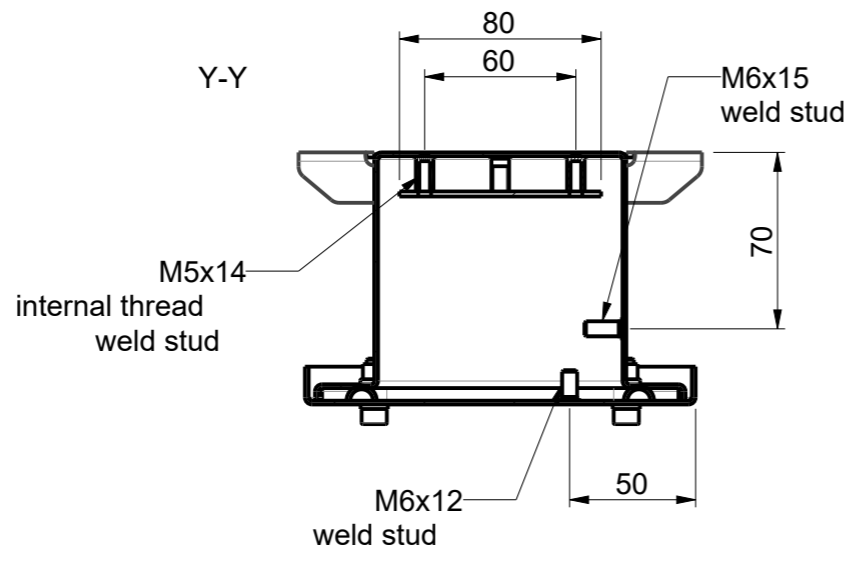
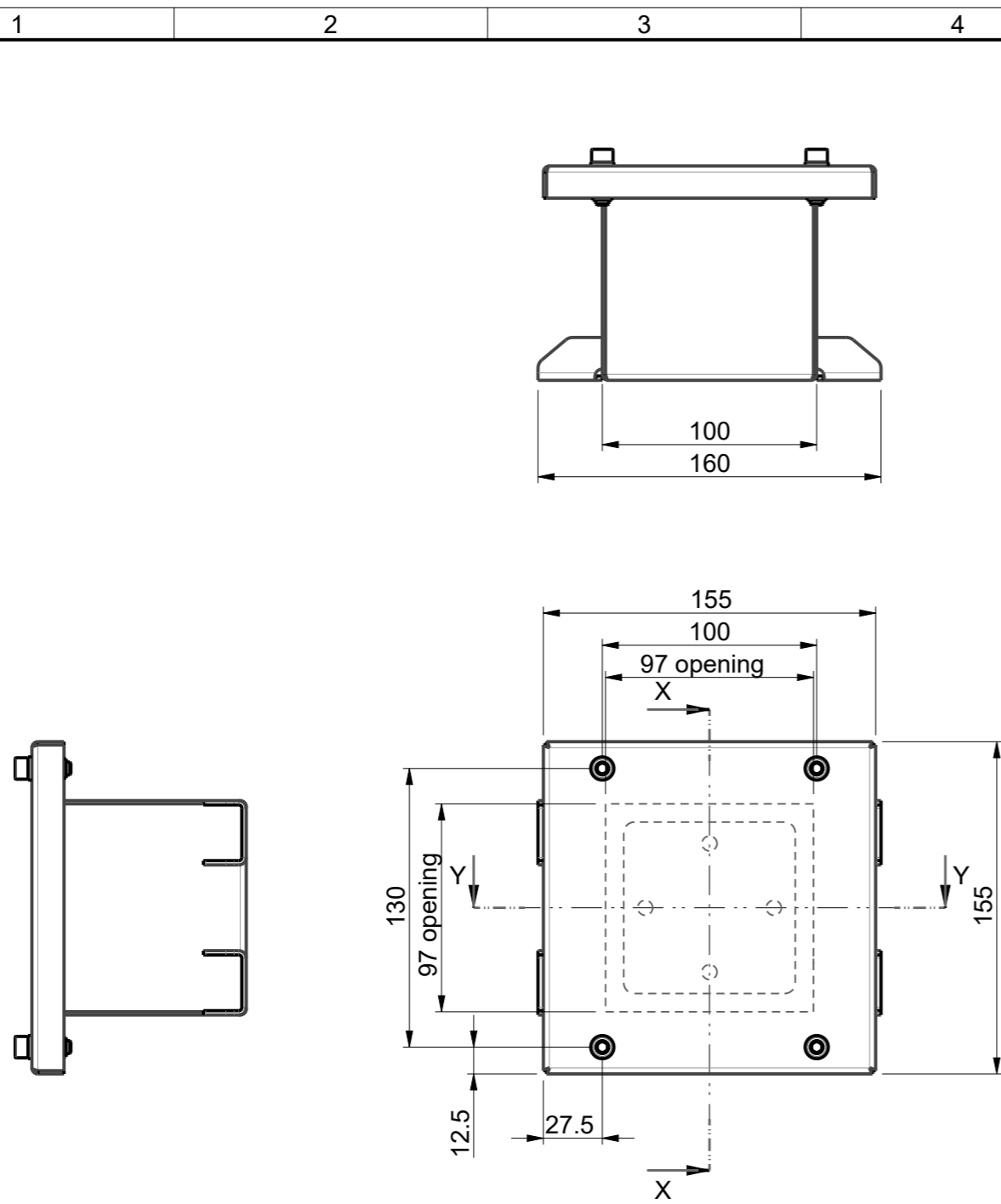

ID	Description	Date	By	Appr.
A	1.	23.7.18	PLe	

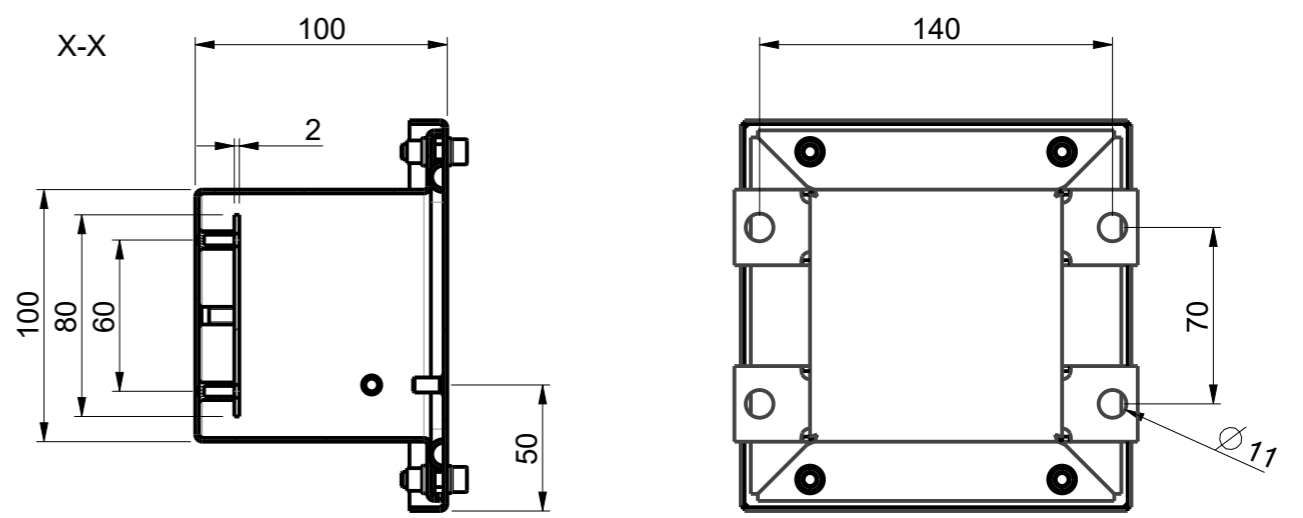

Part	Code	Description	Pcs	Weight [g]/pcs
5	PPE19201	Mounting Plate V1010	1	0
4	PPE19101	Lid VFE1010	1	0
3	PLF33	DIN912 M6x20 A4 hex socket screw	4	0
2	PUA84	DIN125 M6 A4 Washer	4	0
1	PPE19001	Base VFEP101010	1	0

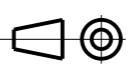
Surface Treatment:		Color: RAL7035S		Weight [g]	1000
Material: Mild steel		Casemet Material:			
CASEMET Casemet Oy				Replaces:	
Scale: 1:3				Replaced:	
Date: 23.7.18				Drw No: A	
By: PLe				Ref: Cubo V	
Checked:		Code: VFEP101010A			
Sheet No: 1 (1)		Ctrl:			