

ISO 2768-C GENERAL TOLERANCES
LINEAR AND ANGULAR DIMENSIONS

DIN 6930-C STAMPED STEEL PARTS
FLAT SURFACES / BENDINGS

ISO 13920-BG WELDINGS
WELDED CONSTRUCTIONS

Model
Drawing VFEP404030A.dwg

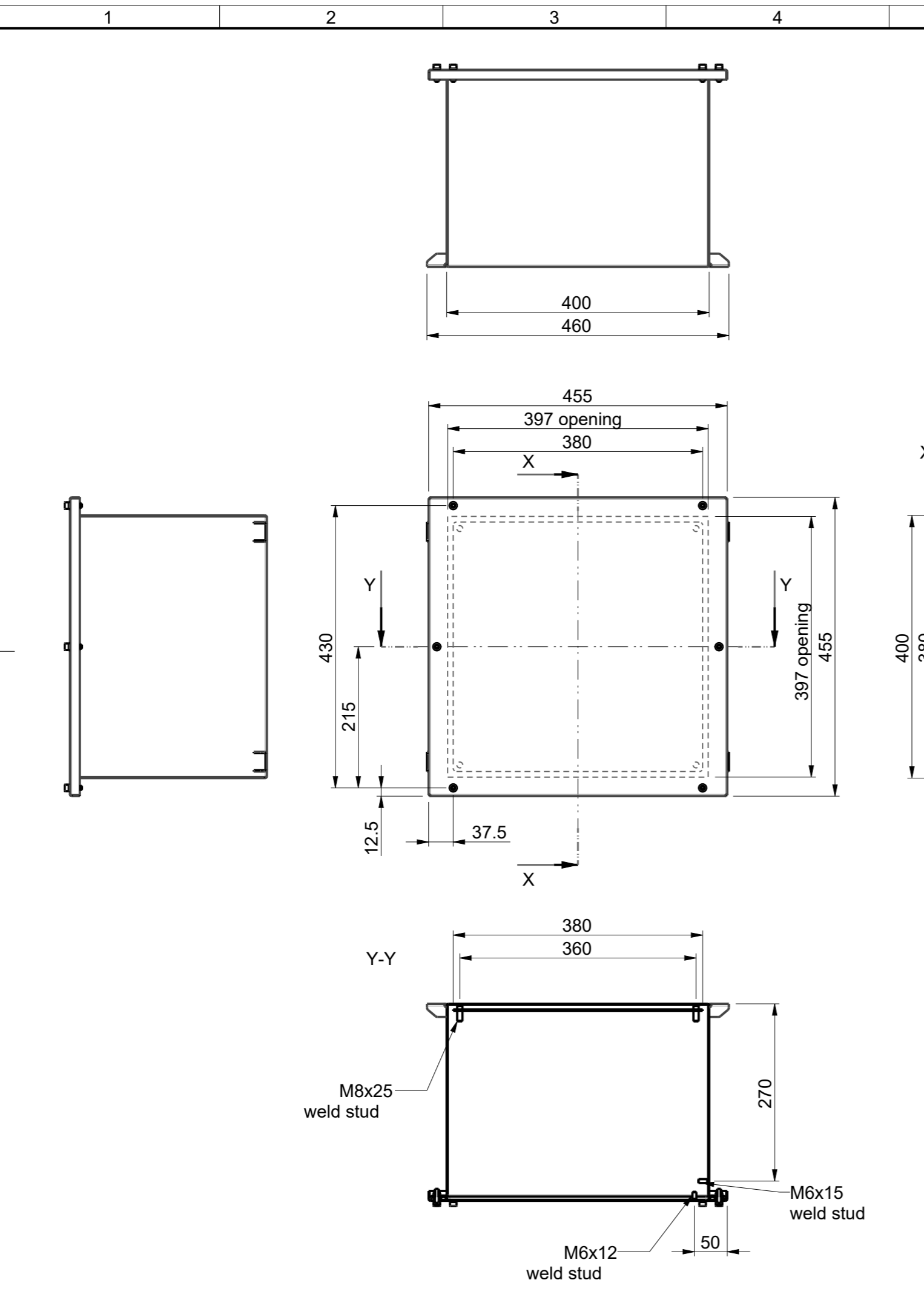

ID	Description	Date	By	Appr.
A	1.	23.7.18	PLe	

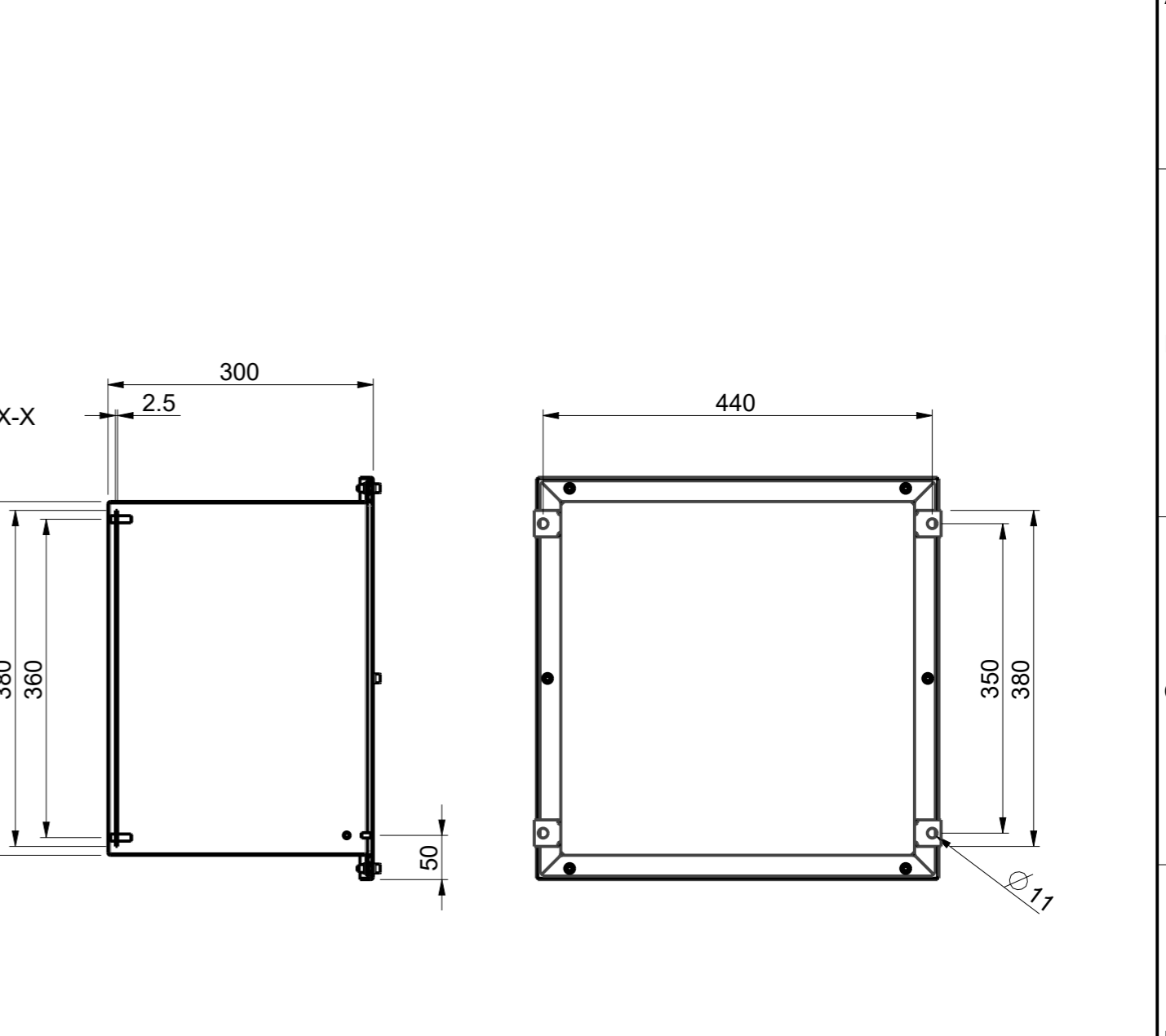

Part	Code	Description	Pcs	Weight [g/pcs]
5	PPE19210	Mounting Plate V4040	1	0
4	PPE19110	Lid VFE4040	1	0
3	PLF33	DIN912 M6x20 A4 hex socket screw	6	0
2	PUA84	DIN125 M6 A4 Washer	6	0
1	PPE19011	Base VFEP404030	1	0

Surface Treatment:		Color: RAL7035S		Weight [g]	11000
Material: Mild steel		Casemet Material:			
 Casemet Oy				Enclosure VFEP404030A	
Scale	Date	Replaces:			
43:300	23.7.18	Replaced:			
A3	By	Drw No: A			
	Checked	Ref: Cubo V			
Sheet No: 1 (1)	Ctrl	Code: VFEP404030A			