

ISO 2768-C GENERAL TOLERANCES  
LINEAR AND ANGULAR DIMENSIONS

DIN 6930-C STAMPED STEEL PARTS  
FLAT SURFACES / BENDINGS

ISO 13920-BG WELDINGS  
WELDED CONSTRUCTIONS

Model Drawing VSSP202010.dwg

1 2 3 4 5 6 7 8

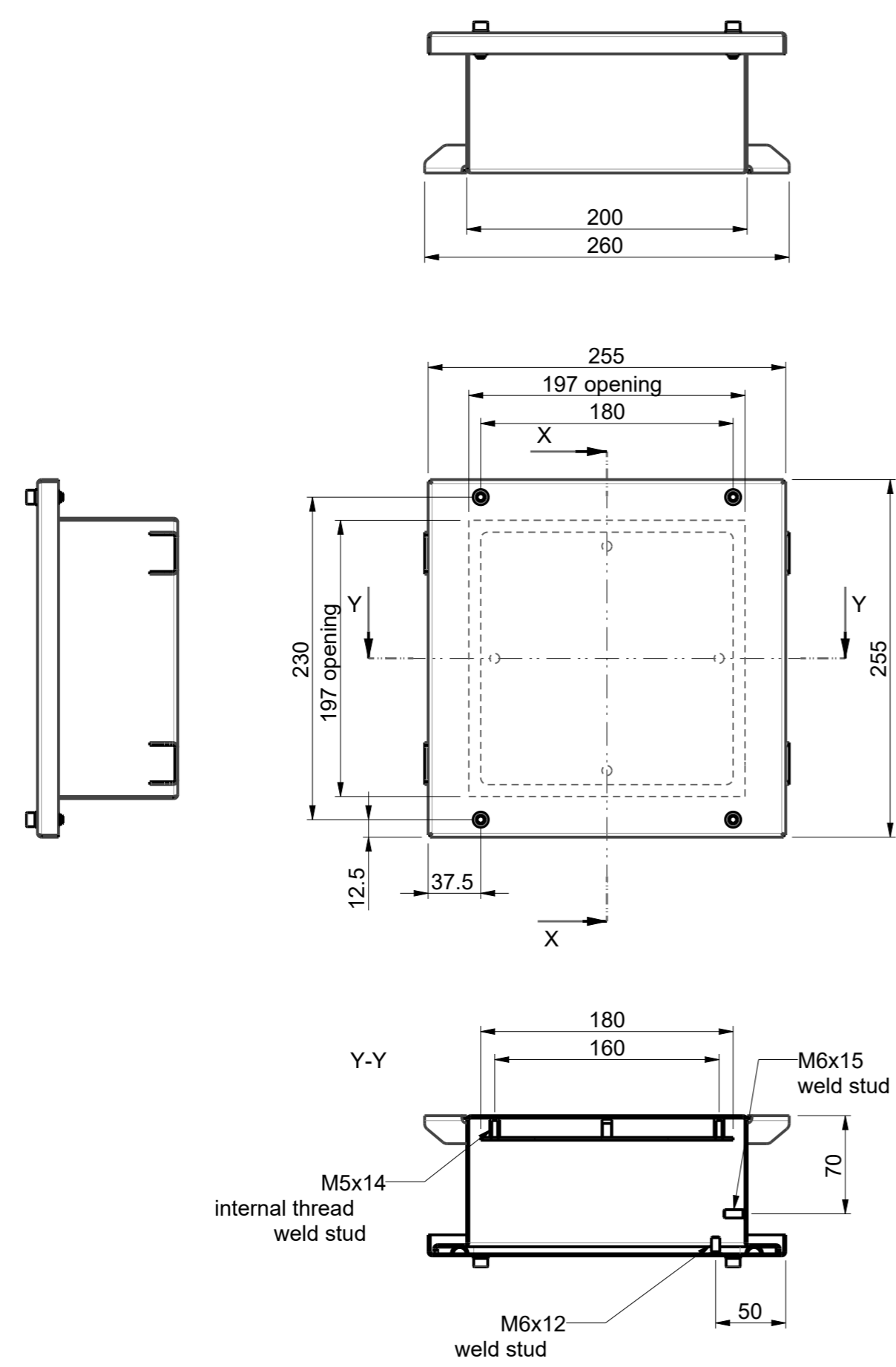

ID	Description	Date	By	Appr.
A	1.	23.7.18	PLe	

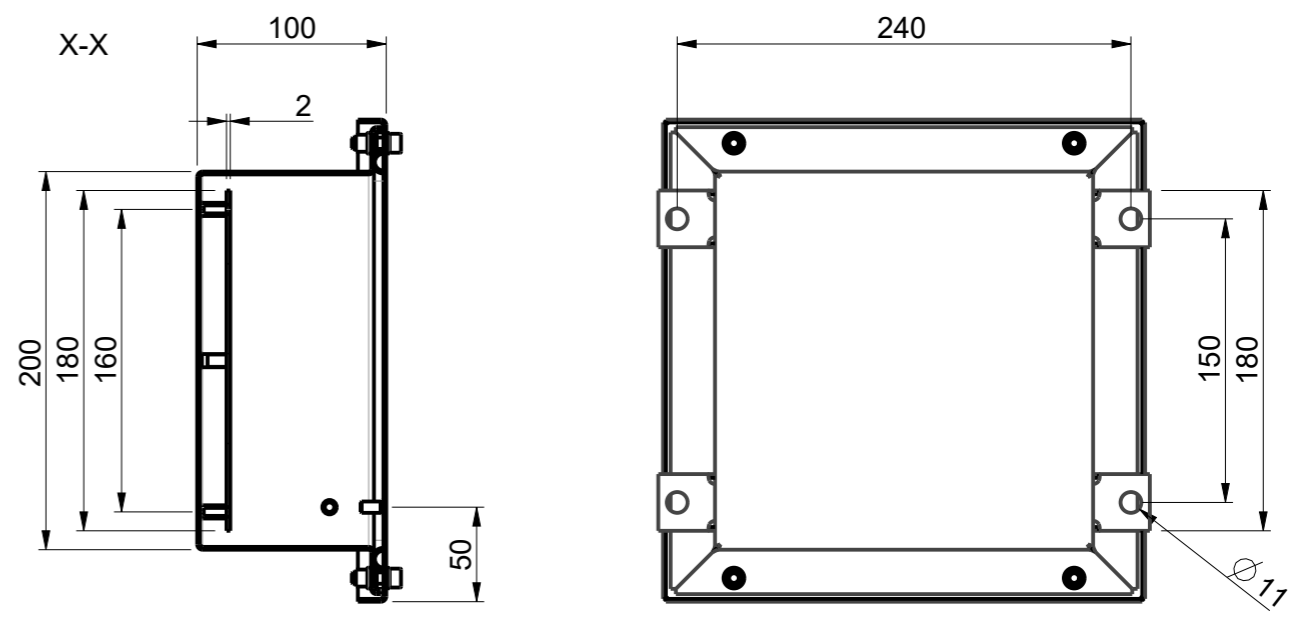

Part	Code	Description	Pcs	Weight [g]/pcs
5	PPE19203	Mounting Plate V2020	1	0
4	RST12103	Lid VSS2020	1	0
3	PLF33	DIN912 M6x20 A4 hex socket screw	4	0
2	PUA84	DIN125 M6 A4 Washer	4	0
1	RST12003	Base VSSP202010	1	0

Surface Treatment:	Color: -	Weight [g]	2000
Material: Stainless steel	Casemet Material:		

			Enclosure VSSP202010	Replaces:
Casemet Oy				Replaced:
Scale	Date	23.7.18	Drw No: <b>A</b>	Ref:
1:4	By	PLe		Cubo V
A3	Checked			Code: VSSP202010
Sheet No: 1 (1)	Ctrl			